

Fig. 4/26
Data exchange between CBC boards with bus interruption

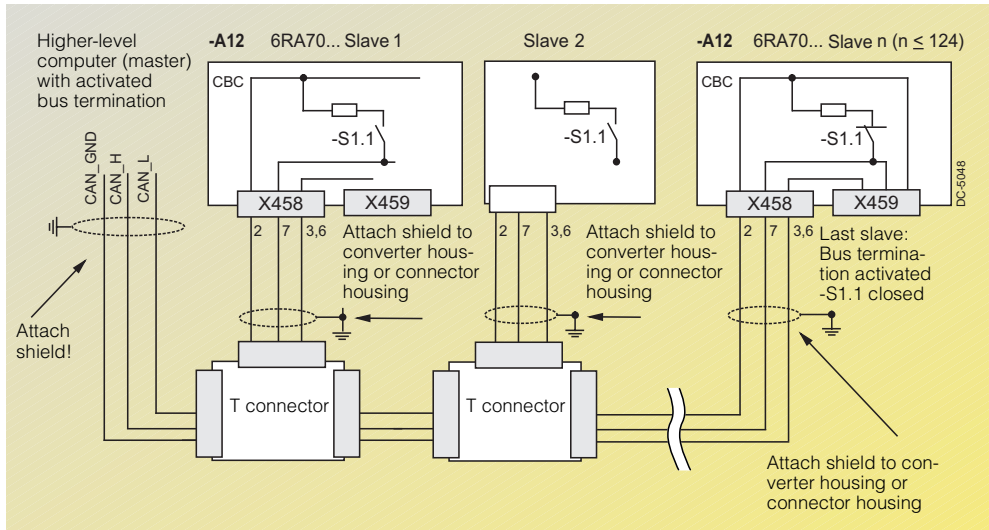
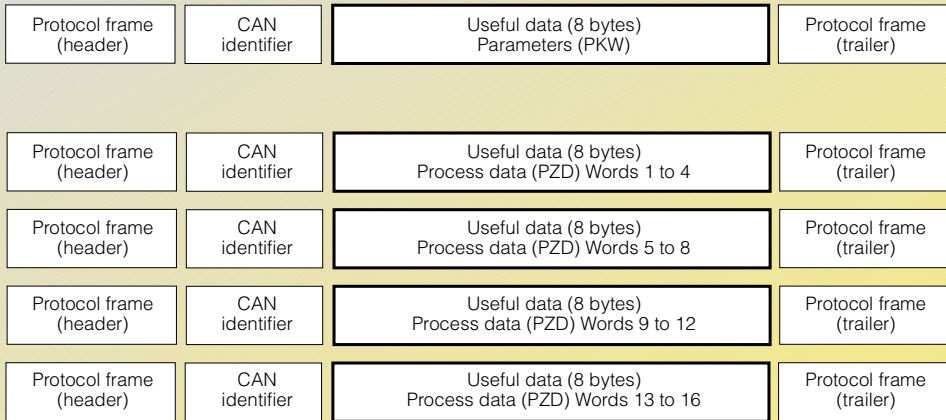

Fig. 4/27
Data exchange between CBC boards without bus interruption



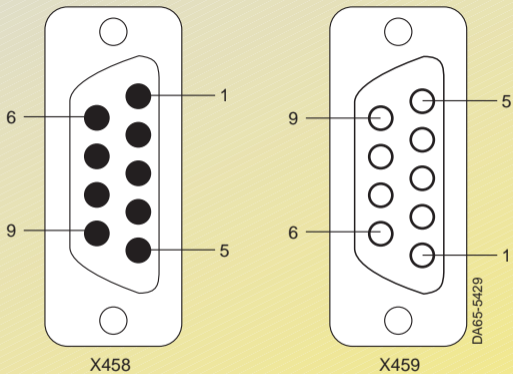

Fig. 4/29
X458 (plug) and X459 (socket) connections