

SIMOTICS SD 1LP Standard Motors

Dimensions

Cast-iron series 1LP4
Frame sizes 180 M to 315 L

Dimensional drawings

Type of construction IM B3

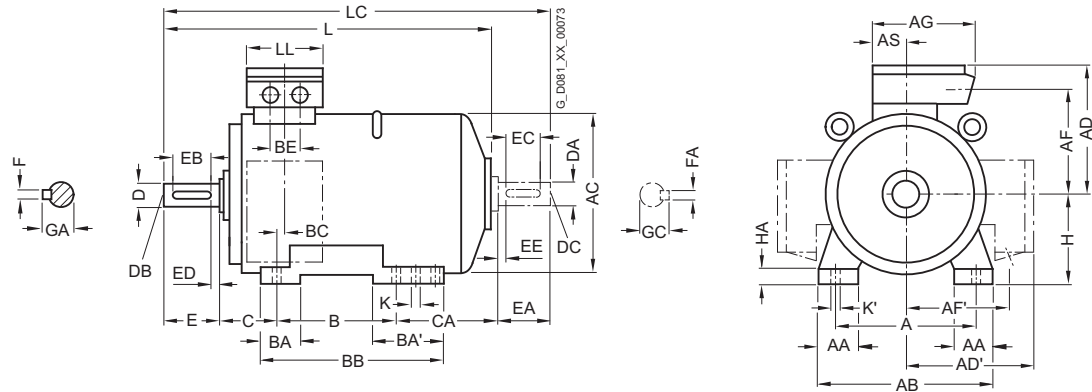

Frame sizes 180 M/L, 225 S/M, 280 S/M and 315 S/M/L have frame feet each with 2 drilled holes at NDE.

Types of construction IM B5 and IM V1 (IM B5 only up to frame size 315 M)

For flange dimensions, see section flange dimension (Z = the number of retaining holes)

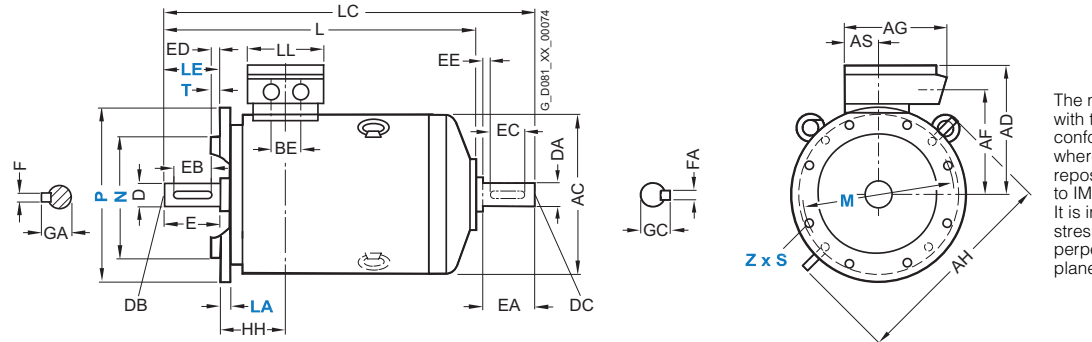

The motors are supplied with two screw-in eyebolts conforming to IM B5, whereby one can be repositioned to conform to IM V1 or IM V3. It is important to note that stress must not be applied perpendicular to the ring plane.

For motor		Dimension designation acc. to IEC																					
Frame size	Type	Number of poles	A	AA	AB	AC	AD	AD'	AF	AF'	AG	AH	AS	B*	BA	BA'	BB	BC	BE	C	CA*	H	HA
180 M	1LP4183	2, 4	279	65	339	363	262	262	220	220	152	452	71	241	70	111	328	36	54	121	94	180	20
180 L	1LP4186	4, 6, 8	279	65	339	363	262	262	220	220	152	452	71	279	70	111	328	36	54	121	56	180	20
200 L	1LP4206	2, 6	318	70	378	402	300	300	247	247	260	512	96	305	80	80	355	63	85	133	76	200	25
	1LP4207	2, 4, 6, 8	318	70	378	402	300	300	247	247	260	512	96	305	80	80	355	63	85	133	76	200	25
225 S	1LP4220	4, 8	356	80	436	442	325	325	272	272	260	556	96	286	85	110	361	47	85	149	99	225	34
225 M	1LP4223	2	356	80	436	442	325	325	272	272	260	556	96	311	85	110	361	47	85	149	74	225	34
		4, 6, 8																					
250 M	1LP4253	2	406	100	490	495	392	392	308	308	300	620	118	349	100	100	409	69	110	168	111	250	40
		4, 6, 8																					
280 S	1LP4280	2	457	100	540	555	432	432	348	348	300	672	118	368	100	151	479	62	110	190	137	280	40
		4, 6, 8																					
280 M	1LP4283	2	457	100	540	555	432	432	348	348	300	672	118	414	100	151	479	62	110	190	86	280	40
		4, 6, 8																					
315 S	1LP4310	2	508	120	610	610	500	500	400	400	380	780	154	406	125	176	527	69	110	216	168	315	50
		4, 6, 8																					
315 M ¹⁾	1LP4313	2	508	120	610	610	500	500	400	400	380	780	154	457	125	176	527	69	110	216	117	315	50
		4, 6, 8																					
315 L ¹⁾	1LP4316/317	2	508	120	610	610	500	500	400	400	380	780	154	508	125	176	578	69	110	216	226	315	50
		4, 6, 8																					

* This dimension is assigned in DIN EN 50347 to the frame size listed.

¹⁾ With order codes for connection box positions (K09, K10, K11) only fitted feet with 3 drilled holes with dimension "B" (406, 457 and 508 mm). BB will then be 666 mm.

Dimensional drawings (continued)

Type of construction IM B35

For flange dimensions, see section flange dimension (Z = the number of retaining holes)

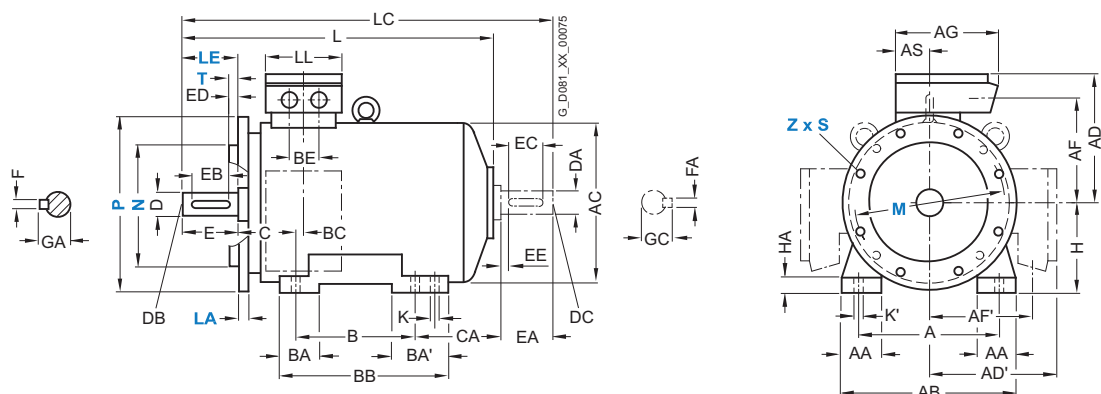

For motor		Dimension designation acc. to IEC							DE shaft extension					NDE shaft extension								
Frame size	Type	Number of poles	HH	K	K'	L	LC	LL	D	DB	E	EB	ED	F	GA	DA	DC	EA	EC	EE	FA	GC
180 M	1LP4183	2, 4	157	15	19	562	676	132	48	M16	110	100	5	14	51.5	48	M16	110	100	5	14	51.5
180 L	1LP4186	4, 6, 8	157	15	19	562	676	132	48	M16	110	100	5	14	51.5	48	M16	110	100	5	14	51.5
200 L	1LP4206	2, 6	196	19	25	617	734	192	55	M20	110	100	5	16	59	55	M20	110	100	5	16	59
	1LP4207	2, 4, 6, 8	196	19	25	617	734	192	55	M20	110	100	5	16	59	55	M20	110	100	5	16	59
225 S	1LP4220	4, 8	196	19	25	670	784	192	60	M20	140	125	10	18	64	55	M20	110	100	5	16	59
225 M	1LP4223	2	196	19	25	640	754	192	55	M20	110	100	5	16	59	48	M16	110	100	5	14	51.5
		4, 6, 8				670	784		60	M20	140	125	10	18	64	55	M20	110	100	5	16	59
250 M	1LP4253	2	237	24	30	764	878	236	60	M20	140	125	10	18	64	55	M20	110	100	5	16	59
		4, 6, 8					908		65	M20	140	125	10	18	69	60	M20	140	125	10	18	64
280 S	1LP4280	2	252	24	30	830	975	236	65	M20	140	125	10	18	69	60	M20	140	125	10	18	64
		4, 6, 8							75	M20	140	125	10	20	79.5	65	M20	140	125	10	18	69
280 M	1LP4283	2	252	24	30	830	975	236	65	M20	140	125	10	18	69	60	M20	140	125	10	18	64
		4, 6, 8							75	M20	140	125	10	20	79.5	65	M20	140	125	10	18	69
315 S	1LP4310	2	285	28	35	925	1070	307	65	M20	140	125	10	18	69	60	M20	140	125	10	18	64
		4, 6, 8				955	1100		80	M20	170	140	25	22	85	70	M20	140	125	10	20	74.5
315 M ¹⁾	1LP4313	2	285	28	35	925	1070	307	65	M20	140	125	10	18	69	60	M20	140	125	10	18	64
		4, 6, 8				955	1100		80	M20	170	140	25	22	85	70	M20	140	125	10	20	74.5
315 L ¹⁾	1LP4316/317	2	285	28	35	1085	1230	307	65	M20	140	125	10	18	69	60	M20	140	125	10	18	64
		4, 6, 8				1115	1260		80	M20	170	140	25	22	85	70	M20	140	125	10	20	74.5

¹⁾ With order codes for connection box positions (K09, K10, K11) only fitted feet with 3 drilled holes with dimension "B" (406, 457 and 508 mm). BB will then be 666 mm.